

Anzeiger

Oregon Region Porsche Club of America
January-February 2002 v42-n1

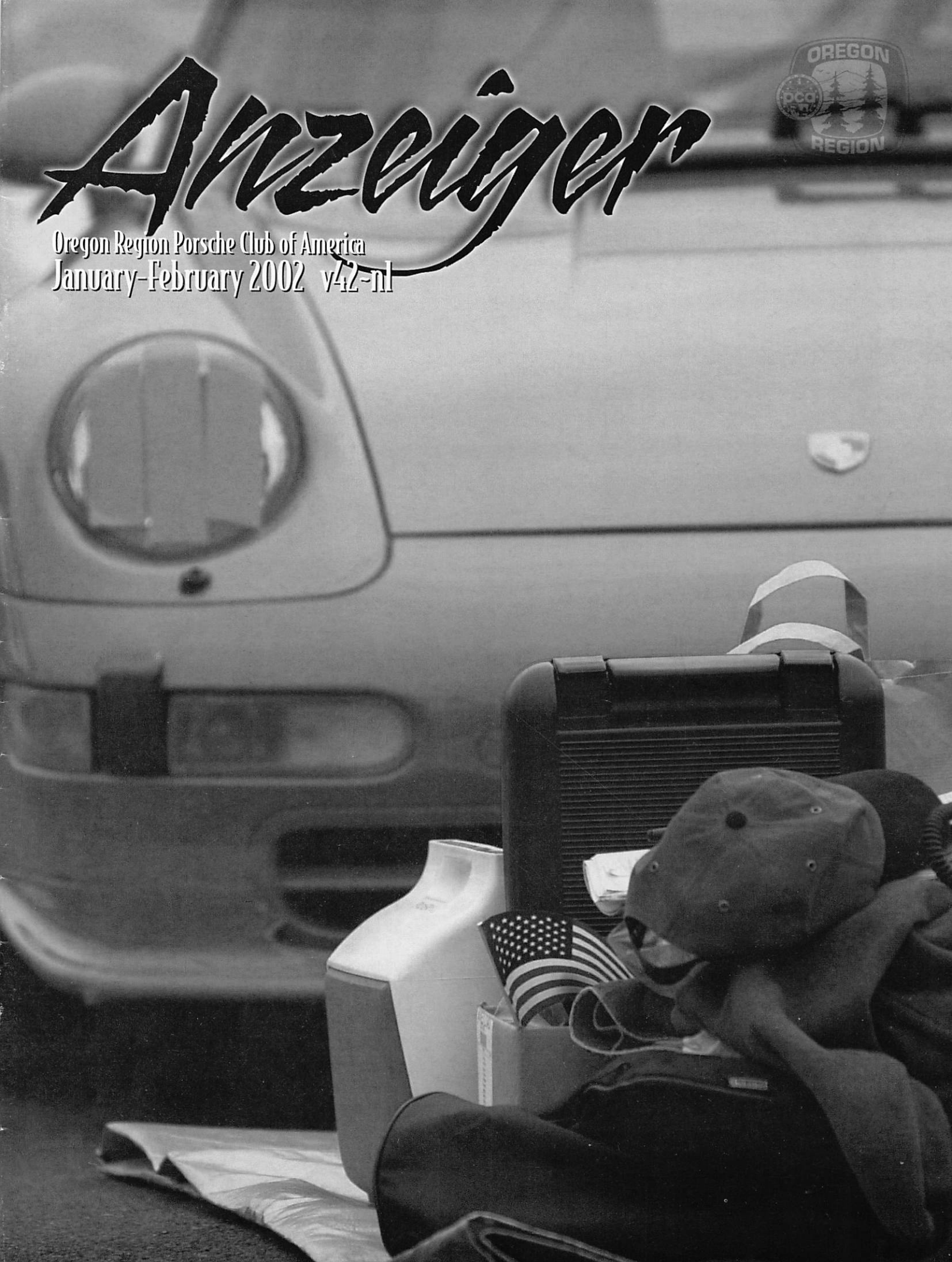

**You may not remember the color of your first love's eyes.
But you'll never forget her paint job.**



It's okay.

To Carrera Motors, that kind of passion for a Porsche is quite natural. Because we share your love for the superior engineering, style and performance of the finest German automobiles. In fact, that's all we sell: Porsche, BMW, Audi and Volkswagon.

We also understand your need for knowledgeable consultants and impeccable service. Maybe that's why we're the number one Porsche dealer in Oregon. And why we rank among the top dealers nationwide in customer satisfaction, year after year.

We invite you to call or visit our superb showrooms. We'd be happy to help you find your perfect match.

Carrera
MOTORS
Driving Central Oregon

OREGON'S #1 PORSCHE DEALER

IN STOCK

- 02 Carrera Cabriolet Slate Grey/Grey
- 02 Carrera Coupe Artic Silver/Black
- 02 Boxster Slate Grey/ Black
- 02 Boxster Artic Silver / Black
- 01 Boxster S. Lapis Blue / Grey

PRE-OWNED

- 01 Carrera 4 Coupe Black / Black "sport" 4k
- 99 Carrera 4 Coupe. Black / Black 21k
- 99 Carrera Coupe Met. Black / Black 22k
- 99 Carrera Coupe. Arena Red / Grey
- 99 Carrera Cabriolet Silver / Black 19k
- 99 Boxster Arena Red / Grey
- 98 Boxster Silver / Black 29k
- 98 Boxster Ocean Blue / Savanna 27k
- 89 Speedster White / Black (collector condition)

INCOMING

- 02 Carrera Cabriolet. Modifiable (Dec)
- 02 Boxster S Black / Black
- 02 Boxster Seal Grey / Grey (TIP)
- 02 OPEN builds available....



Anzeiger

An Award-winning
Publication of the Oregon Region
Porsche Club Of America

(an' zi ger), n. Ger.
1. One who points out,
indicates, shows.
2. One who informs.

Editor
Sue Hodge
21000 S. Mossy Rock Ct.
Oregon City, OR 97045
503.518.9203 ~ sghodge@bctonline.com

Display Advertising
Chris Greenwood, 503.460.9494

Classified Advertising
Classified ads are free to PCA/OR members. More information may be found in the "Marketplace" section near the back of the magazine.

Non-members wishing to place non-commercial classified advertising may do so, and are limited to one submission. The rate for 50 words or less is \$12.50 for one issue. Include a check or money order made payable to The Oregon Region of the PCA accompanying the submission. Placement of non-member classified ads depend on the availability of space after all member ads have been included. **More information can be found in the "Marketplace" Section.**

Anzeiger is the official publication of the Oregon Region of the Porsche Club of America, Inc., P.O. Box 5652, Portland, Oregon 97228-5652, and is published on a monthly basis. Non-member subscription rate is \$28.00 annually. Third Class Postage is paid at Portland, OR.

Statements made in the *Anzeiger* are those of the authors and do not necessarily constitute the opinion of the Porsche Club of America, The Oregon Region, the Board of Directors or the editor. The editor reserves the right to edit, as necessary, all materials submitted for publication. Permission to reprint or reproduce articles may be granted by the editor or the respective author(s). Photographs may not be reproduced. Electronic versions of this document may only be distributed by the the Region's official web site of record. PCA/OR Region is not responsible for any services and/or merchandise advertised herein.

Postmaster:
Send address changes to:
PCA/OR Membership Chair
Russ & Sharon Pascoe
2955 Argyle Drive S
Salem, OR 97302

Graphic Design/Layout
Chris Greenwood
4403 NE 9th Ave
Portland, OR 97211
503.460.9494
chris@chrisgreenwood.com

Printed By:
Dempsey & Campbell
Portland, OR

© Copyright 2002
Oregon Region
Porsche Club Of America.

All content © Copyright
the respective
contributors.

v42-n1

Anzeiger

2002
JAN-FEB

Feature Stories

<i>From the President/Editor</i>	4
<i>Rear View Mirror</i>	8
<i>2001 Holiday Party</i>	10-11
<i>2001 Rainbonnet</i>	12-13
<i>Tech Stop</i>	18

Club Information

<i>Club Calendar</i>	5
<i>Porsche Parade 2002</i>	6
<i>Vintage Iron Tour IV</i>	6
<i>Tech Session</i>	7
<i>Ski Weekend</i>	7
<i>Go Karts and Lunch</i>	8
<i>Marketplace</i>	20

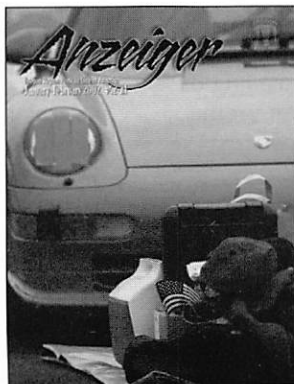

Cover image:
Scenes from Driver's Ed/Rainbonnet @ PIR.
Photo by Chris Greenwood

Please check our web site often:

<http://oregonpca.org/>



Don Clinkinbeard
FROM THE PRESIDENT

about 112 from 125mph. This is probably going to cost a few bucks to correct. In this time of a less than strong economy, how do I save costs while restoring (or maybe even improving) the performance of my wonderful charging black stallion? Well, one option is doing some of the work myself. It'll certainly take more time, both calendar and personal, to get the results I want. I might make a few mistakes on the way, loose a few knuckles, but I've always gotten there in the past. Last winter I replaced the entire suspen-

events. While our club is on solid financial footing and operating well, expense management will be something that needs to stay in the forefront of our event chairs' minds while searching the horizon for new opportunities to engage more members in our events.

One of our first steps in this effort to contain and/or reduce expenses, while learning to do it ourselves, is to look at the various forms of communication available and see if there is a way to effectively communicate with the membership for a lower cost than we currently incur. Ken Blanchard (Vice President and Director of Communications and Publications) has taken up this challenge and will be keeping you informed as we move forward through the year.

As we start 2002, our Rainbonnet Chair team for the last two years, the most capable Duncan and Michele Crebbin, have decided not to take on another year of organizing this premier event for our region. They tell me that they will be around to advise the new leader though. I'm looking for someone to step up and take on this leadership challenge really soon. We already have folks to organize the concours, handle registration, run the Goodie Store and manage the track day. We need someone to coordinate all this

continued on page 18

I'm sitting here on this dreary November day watching the rain drip off the eaves of my home and thinking, well, the 944 Turbo needs some engine work. It's been slowing down over the past year. Lap times at PIR (clocked off of the track video tapes at home) have slipped by 7 seconds, and my accelerometer says the rear wheel HP is down to about 220 from 254 at this time last year. Top speed on the front straight is down to

sion system with a pretty much full race setup and the car handles much better this year. I have more positive control, and get better feedback at the limits. Because of this activity I have confidence I can learn and become competent in most any new skill set I've chosen to develop (well maybe not brain surgery - takes too long.)

The club faces much the same challenges in the coming year. We have already seen the impact of the economic downturn in reduced attendance at some

Sue Hodge
FROM THE EDITOR



little package from PCNA. I thought at first, who sent me an early Christmas present? The package was fit for the mailing of something really cool, like an enameled crest to mount on the car's grille or some other equally neat small (and maybe expensive) trinket. It turned out to be an intro packet for the Cayenne. I have to admit that in spite of myself, I have been caught up in the anticipation to some extent. We have members who have been to the Porsche factory in Stuttgart this fall who were not given a real look at the new SUV. The prototype they saw was shrouded so that about all they could see was the shape. In this packet we received, the cover photo on this "prologue" to the Cayenne story showed us little else. It was a shot

I was going to write the usual January message about all the great events we have planned for the new year coming up and how I'm really looking forward to it (we do, and I am) but.....did you get the same thing in the

mail we did recently? A pretty fancy

of the SUVs at dusk on a dirt track in the middle of the desert. A fitting intro to the story inside.

Both my husband and my son Alex have educated me on the history of Porsche and 4-wheel drive excellence. In my defense, I've also read some of that information on my own, driven by the quest to find out why Porsche would produce an SUV (other than the obvious answer...) The brochure we received capsulized the 959 story, which if you don't know it, is one of the most interesting parts of the heritage of Porsche and all wheel drive. In 1985, a single 959 was entered in the Rallye of the Pharaohs and took 1st place followed by a 1st and 2nd place in the Paris-Dakar in the following year in the African desert. At the time, no one expected this from Porsche but it was clear that these cars were not just sports cars for the rich and frivolous. And the history of 4-wheel drive precedes this milestone.

The final page of the brochure shows the Porsche crest, artfully captured in partial light. The next to the last page is a tantalizing hint of a fascinating story that leads up to the production of this SUV they call the Cayenne. If we returned the response card we would get several more mailings telling the whole story. Well, you can bet we returned the card. I can't wait to see how the message will unfold - and it's not just a story, it is a marketing message as well. From the looks of this first piece, they're doing a great job.

OREGON REGION CALENDAR



January

- 8 Board of Directors Meeting
- 14 First Day to send in Parade Registration
- 16 Dinner Meeting
- 20 Go Karts and Lunch
- 20 Anzeiger Editorial deadline
- 26 Tech Session (Getting your car ready for Spring Driving)

February

- 5 Board of Directors Meeting
- 8-10 Bend Ski Weekend
- 16-17 Audi Track Day
- 20 Dinner Meeting
- 20 Anzeiger Editorial deadline
- 24 Go Karts and Lunch

March

- 5 Board of Directors Meeting
- 10 Vintage Iron Tour IV
- 20 Dinner Meeting
- 20 Anzeiger Editorial deadline
- 22 ORPCA Track Day
- 23 Alfa Track Day
- 29 BMW Track Day

April

- 2 Board of Directors Meeting
- 7 Spring Clean
- 12 ORPCA Track Day
- 14 Go Karts and Lunch
- 17 Dinner Meeting
- 20 Tech Session (Club Racing car preparation)
- 20 Anzeiger Editorial deadline
- 21 Autocross
- 27,28 Kahneeta Tour

May

- 5 Burrito Run
- 7 Board of Directors Meeting
- 10 BMW Track Day
- 11 TSD Rallye School and Rallye
- 15 Dinner Meeting
- 18 Past Presidents Poker Tour
- 19 Autocross
- 20 Anzeiger Editorial deadline
- 31-2 Half a Mille Miglia

June

- 4 Board of Directors Meeting
- 7-9 Rose Cup Races
- 14-16 CART Races
- 20 Anzeiger Editorial deadline
- 22 Progressive Dinner
- 29 Multi-Marqué Track Day

July

- 2 Board of Directors Meeting
- 7 Autocross
- 12-14 Zupan Historic Races
- 20 TSD Rallye
- 20 Anzeiger Editorial deadline
- 25-27 Oregon Romp
- 29 Corvette Track Day
- 28-31 Parade 2002

August

- 1-3 Parade 2002
- 6 Board of Directors Meeting
- 11 Autocross
- 18- Otter Rock Weekend
- 18- Monterey Historic Races
- 16-18 Whistler Weekend
- 20 Anzeiger Editorial deadline
- 21 Win Casey BBQ
- 23 BMW Track Day
- 24 ORPCA Club Picnic TSD Rallye, Tour, Show and Shine
- 30 Lotus Track Day
- 31 British Field Meet

September

- 1 British Field Meet
- 2 Board of Directors Meeting
- 7 ORPCA Volunteer Recognition Party
- 8 Autocross
- 13-15 Sunriver Exotic Car Show
- 18 Dinner Meeting
- 20 Anzeiger Editorial deadline
- 20 Shelby Track Day
- 29 Gorge Tour

October

- 1 Board of Directors Meeting
- 4 ORPCA Track Day
- 6 Autocross
- 12 Alfa Track Day
- 14 Corvette Track Day
- 16 Dinner Meeting
- 20 Singles Tour

November

- 1-3 Rainbonnet 2002
- 5 Board of Directors Meeting
- 9,10 Quattro Track Day
- 20 Dinner Meeting

December

- 3 Board of Directors Meeting
- 7 ORPCA Holiday Party (On the Portland Spirit)

July 26 - August 3



Oregon Region PCA members are encouraged to think about a mid-summer vacation together just east of the Oregon border. We'll have a barrel of fun and we can caravan together for even more fun.

Submit your registration form on time, not early. This point is critical to securing a registration berth. Look for event details in your November Panorama or on the region's web site: www.parade2002.org.

Registration Note

Registration will begin on January 14th and will be accepted only through US mail. Initial registration forms will be sent to PCA offices in Virginia. No couriers or hand-delivered mail is eligible. We have a limit of 650 cars and it's first come, first served. Mail that is post-marked before January 14, 2002, will be ineligible.

Use the registration form in the November issue of Panorama, or log onto the Silver Sage Region web site: www.parade2002.org/registration.shtml

PARADE 2002

BOISER

Willkommen
NEW MEMBERS

- Kyle Peterson1987 911
Tualatin, Or
- Robert Buford2002 911
Portland, Or
- John & Sharon Madden2002 911
Lake Oswego, Or
- Todd & Laila Sanguras1977 911
Hood River, Or

Transfers:

- Diane & Ray Anderson1998 Boxster
Redmond, Or
- R Keaton & Colleen Gildersleeve1986 944
Gaston, Or
- Tracy & Frances Nelson1987 944S
Portland, Or

Anniversaries
JAN-FEB

January/5 Years:

- Robert Fuller
- Bill Brickowski
- Jim & Donna Chapman
- Jeffrey & Yoriko Canaday
- Michael & Paula Clancy
- Craig & Barbara Jorgenson

February/5 Years

- Robert Bigler
- Richard & Lona Azar
- Robert Schmidt
- Gary Emory
- Rickey & Betty Moore
- Scott Foster
- Douglas Burgard
- Gerald & Christina Bonnington

25 Years

- Steve & Pam La Franchi

35 Years

- Buck Peralta

20 Years

- Daniel & Miriam Bertuleit

Vintage Iron Tour IV



Saturday, March, 9 am

Meet at Stark Street Pizza
(9234 S.E. Stark) in Portland
An all-day driving event featuring more
Perfect Porsche Roads, museums &
collections to enjoy.
Cost is \$8 per car.

RSVP by March 3

Hosted by Steve Knepper
(503) 407-6408
and Duanne Luckow.

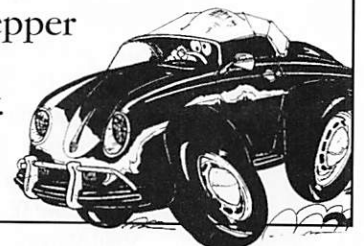

Tech Session - January 26

Club
Event



Sponsored by Rennsport Systems

Topic: Preparation for Spring Driving

We'll discuss all major systems including engine, transmission, suspension, brakes, safety equipment and tires.

Instructor / Speaker:
Steve Weiner

Saturday, January 26 • 9:30 am

Rennsport
19870 SW 129th ave at Herman Rd, Tualatin

RSVP to 503.244.0990

Continental Breakfast Served

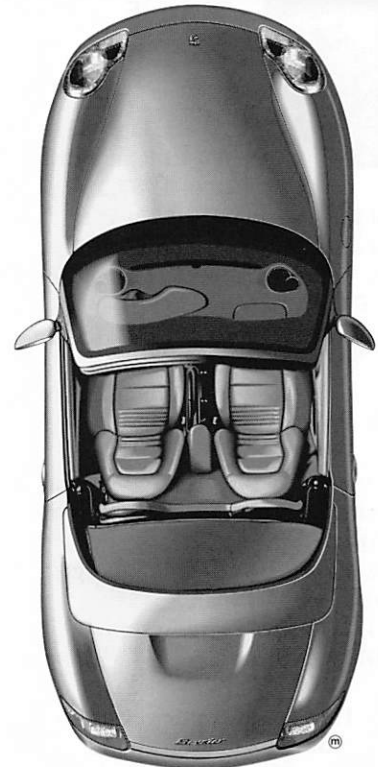

ORPCA SKI WEEKEND

February 8-10, 2002

Mt. Bachelor

Come and enjoy some of the best skiing in Oregon.
Powder snow, great runs for downhill
and the finest cross country trails.

- Lodging at discounted prices for us at the Hawthorne Suites in Bend.
- Friday night reception at John Johansen's house nearby in Broken Top.
- Saturday night social hour and dinner at Robby J's Bistro.
- We will ski Saturday and also on Sunday for those still having the energy.
- High Desert PCA folks will be joining us.

Club
Event

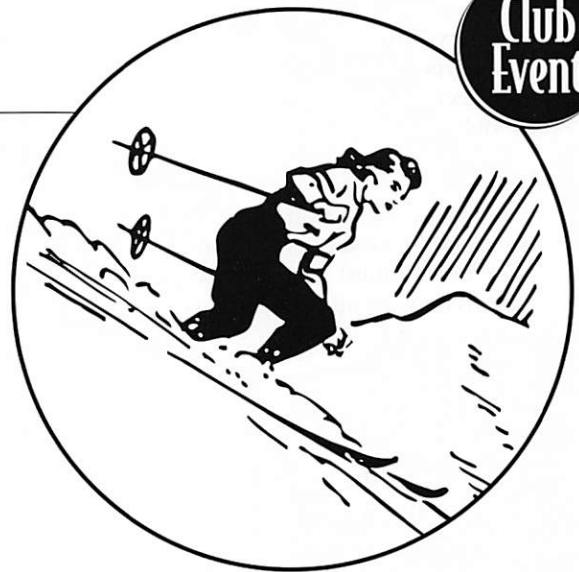

For more information and to make reservations call:

**Jim Neidhart at 503-641-0460 or
John Johansen at 503-228-3827.**

Rear View Mirror

By Peter Linsky



Okay, put on your thinking caps. Time for another quiz for all you Porschenauts. Try these on for size.

1. The late Al Holbert visited P.I.R. in early October of 1987. The purpose of his trip to Portland was to...:
 - a) buy Monte Shelton's 917.
 - b) negotiate a new contract for the 1988 IMSA season.
 - c) oversee the first track test of Porsche's new Indy car.
 - d) test a new Tiptronic gearbox for the Lowenbrau 962.
2. Identify the artist who created many of Porsche's early racing posters.
 - a) Richard von Frankenberg
 - b) Julius Weitman
 - c) Jurgen Lewandowski
 - d) Erich Strenger
3. Five American drivers were on the grid for the 1959 US Grand Prix at Sebring, Florida. Only one of them finished, driving an F2 Porsche 718 with a full body and central seat. Who was this driver?
 - a) Harry Blanchard
 - b) George Constantine
 - c) Roger Ward
 - d) Bob Said
 - e) Phil Hill
4. Speaking of Al Holbert, his father was also a very successful Porsche pilot. Bob Holbert notched the SCCA E Sports racing title in which years?
 - a) 1958-1959
 - b) 1959-1960
 - c) 1960-1961
 - d) 1961-1962
5. Let's go to the movies! Which of the following actors/actresses tossed out the on-screen comment, "Ferrari is a dirty word!"? (Apologies to John and Duncan!)
 - a) Steve McQueen
 - b) Jimmy Cagney
 - c) Kathleen Turner
 - d) Sean Connery

answers on page 16



Go Karts & Lunch

Hot Tracks - Indoor Karting
January 20, February 24: 10:00 am
14010 NE 3rd Ct, Vancouver

Club
Event

Vancouver/Portland's World Class Indoor Go-Kart Track! Share the Excitement!

Yes, its true! You to can be a part of the thrill of driving in close contact with your ORPCA friends. As many as 16 karts can be on the track at a time. All karts are timed for best lap and a spreadsheet is given at the end of a heat detailing your driving skills in best to worst laped time.

Expected pricing is \$14 per heat, maybe less if we gather enough drivers. Each heat is about 14 laps with the two warm-up laps.

Remember to visit the ORPCA web site for the Hot Tracks web site info and directions.

RSVP to Craig Cartwright: 360.573.4887
Plan to grab some lunch afterwards at Billygan's Roadhouse in Hazel Dell.

ClearBra™

"Clearly the Best Protection"

What is ClearBra?

ClearBra is an "RGD" (Ricochet Graduated Density) film. It is clearly the logical alternative to traditional naugahyde bras which can "protect" only a portion of your car's paint. ClearBra actually does protect the paint and lets you see all of it, all the time.

Originally produced to military specifications, ClearBra now covers the consumer market, and is used on RVs, race cars, horse trailers, boats & boat trailers, semis, motorcycles and much more. ClearBra provides the ultimate protection for hood, headlights, fenders, quarter panels, parking lights; virtually any vehicle surface that is at risk from rock damage.

ClearBra is composed of 2 layers, yet is still gas-permeable. That means that your paint can still breathe and age naturally. At 12, 20 or 40 mils thick, ClearBra's hard outer layer bonded to a soft inner layer produces a trampoline effect for objects striking the surface. ClearBra's impact resistance is many times greater than single-ply films. And, ClearBra is the only material designed for abrasion resistance.

Accept no substitutes. Call us today for an estimate of your priceless vehicle.

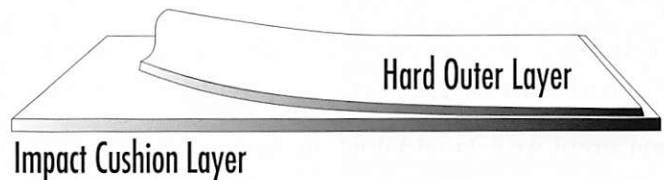

This owner wrapped the nose and complete hood of his M5 with ClearBra.



The ClearBra Advantage

- Custom fitting covers surfaces much more completely than pre-cut template material
- Large sheet sizes ensure seamless coverage of complete hoods and body panels.
- Enhances the beauty of your car
- Minimizes chipping, scuffing and abrasion
- Longer headlight and paint life
- Preserves the appearance (and value) of your car
- Reduces maintenance cost
- No thermal cracking
- UV inhibitors resist yellowing and cracking

ClearBra™ of Oregon, Inc.
2020 NW Aloclek Dr #118
Hillsboro, OR 97124

503.439.9031

1.888.439.9031 (toll-free in Oregon)

ORPCA Holiday Party

By Susan Falleur • Photos by Chris Greenwood

The ORPCA Holiday party provided a marvelous start to the season of sharing and celebrating. The Multnomah Athletic Club, with its elaborate, large scale Christmas trees and ever-green swags enhanced by large white ornaments, was the backdrop for 96 ORPCA members and guests who braved the wind and rain of December 1 to join the last event of the year.

Upon arrival, we enjoyed a drink and delicious hors d'oeuvres while greeting old friends and meeting new ones. I couldn't help noticing how nice people looked. Debra Clinkinbeard was lovely in a floor length raspberry gown, Nadine Lowe's black velvet choker perfectly complimented her silver and black dress, and our resident artist, Alan Nies, looked like an American flag in his white suit and tie with a red and blue shirt. George Baker overcame a tai chi injury to appear, very spiffy in his dark shirt and bow tie.

Amidst a broad assortment of appealing offerings, this year's Silent Auction featured several baskets, and our creative members ensured no two were alike. There were baskets for holding a tea party (thanks to our British import, David Williams and his wife Nan), one for chocolate lovers, and several with geographic themes — France, Australia, and Hawaii. From the

Blanchards came an elaborate basket for enjoying the beach, complete with a Porsche blanket and beach games. There seemed to be a basket for every interest, from cheese and wine to dog lovers.

One of the most popular items, to judge by the length of the bidding sheet, was a garden cart filled with useful items from leather gloves to an iced tea set. The eventual winner used an effective strategy, explaining to competing bidders why it was needed because it was "perfect for my small yard." Repeat donations from previous years generated spirited bidding, including weekends at the Cannon Beach and Salishan beach homes of John and Carlyn Draneas and Jeannie and Jeff Gretz. Rupert and Bobby Jo Koblegarde's gourmet dinner for 8 brought a high bid, as did several bottles of vintage wine. Of course, there were many Porsche items:

posters, an autographed hat, plaques, books, magazines, and a beautiful stained glass tribute to the Targa. Alan Nies once again generously donated one of his original works, a serigraph of the Gulf Porsche team in action. Many members bid on the car handling course donated by Bart Locanthi. Chris



Above: Registrars extraordinaire, Kay Rhoney, Don & Joan Palmer. Left: Erica Nance presents Sharon Pascoe with the coveted "Gear of the Year" Trophy.

Greenwood offered one of his beautiful photographs, a framed shot of vintage 917s.



Special Guests Stephen Guntli of the Dougy Center and wife

In addition to organizing the Silent Auction, our auction committee found the time to include a Chinese raffle featuring items from the Dougy Center children's art class. A ceramic bunny, cookie jar, and several Porsche ceramic models with imaginative paint jobs were very popular, and will be treasured by the winners. A few of the other items were a black leather bag and T-shirts courtesy of

Tweeks, a Porsche bear from Sue and Greg Hodge, a keg of beer courtesy of Widmer Brewing, and Stongard headlight protectors from Bill Shores.



It's a long story, but these are Very Important Porsche People. They're the ones who make the club work, get it from place to place and do it with a smile.

Ted Coleman announced that over \$6,000 was generated by the Silent Auction, and another \$350 from the Chinese Raffle. The Dougy Center and the Raphael House will receive donations from ORPCA.

Congratulations and thank you for a well organized and successful raffle and auction goes to the committee chaired by Tom and Linda Jewett, with excellent assistance from Ted and Karyn Coleman and Don and Joan Palmer. After dinner (choice of salmon or pork, both delicious from all reports), President Carol Beutz introduced our PCA Zone 6 representative, Dick Grant. Expressing his appreciation to Carol for her past two years of service as our president, Dick complimented her on her thoroughness in ensuring our Club received every source of funding available from the national organization, and presented her with a check for an additional \$850. He invited the ORPCA membership to attend the national Porsche Parade in Boise scheduled for July 28-August 3, 2002.

Our special guest, Stephen Guntli, Executive Director of the Dougy Center, thanked the membership for our support. The Center's work with grieving children included those who lost parents and siblings in the September 11 tragedy.

Our traditional Very Important Porsche Person awards, along with our major annual awards, were next announced. The recipients received their awards in very colorful gift bags, stuffed with bright Porsche red, black and yellow decorations. Outgoing board members were presented with sports vests embroidered

continued on page 14

Very Important Porsche People

Bader, Dick	Track, Club Race, Rainbonnet
Baker, George	Braillye Rallye, Nomination Comm.
Baker, Jeff	Braillye Rallye
Baker, Ron	Braillye Rallye
Casey, Win	Win Casey Bar B Que
Coleman, Ted & Karlyn	Holiday Party
Culbertson, Jay	Rose Cup
Fasching, Kirsten	Classified Adv. Editor
Gamroth, Jeff	Tech Sessions
Geny, Travis	Anzeiger Contributor
Graham, Maggie	Braillye Rallye
Grant, Dick	Zone 6 Rep.
Greenwood, Chris	Anzeiger Contributing Editor
Gretz, Jeannie	Anzeiger Contributor
Herron, Nancy	Social Events
Holder, Karen	Anzeiger Contributor
Jewett, Tom & Linda	Advertising Manager, Holiday Party
Johnanson, John	1/2 Millie
Jolly, Pat	Progressive Dinner
Jordan, Michael	Tech Sessions
Knepper, Steve	Vintage Iron Tour III
Ledbetter, Gordon & Randi	Tech Session, Club Race
Leipzig, Kurt	Tech, Club Race
Lowe, Warner	Nomination Comm
Luckow, Duane	Garage Tour
Malhoney, Richard & Sharon	Progressive Dinner
Mazmanian, John	Anzeiger Contributor
McEuen, Bob & Marlene	CART Tickets, Rose Cup, Club Race, AMLS
McNab, Teri	Goodie Store
Palmer, Don & Joan	Holiday Party
Puetz, Richard	Otter Rock, Hot Trax
Shores, Bill	Sunriver
Singer, Dave	Tech, Club Race, Anzeiger Contributor
Sironen, Deb	Rainbonnet, Goodie Store
Stroum, Don & Mary K	Progressive Dinner
Stroum, Don Jr.	Anzeiger Contributor
Tarket, Steve	Club Race
Thacker, Rick	Webmaster
Williams, David	Club Race, Anzeiger Contributor
Wilmoth, Peter	Anzeiger Contributor

The following individuals donated items to the Porsche Party Silent Auction on December 1, 2001:

AAA Oregon/Idaho
 AMSOIL, Greenwood Marketing
 A-n-T Tire & Wheel
 Baker, George & Sandy
 Baker, Syd & Janet
 Blanchard, Ken & Sue
 Clinkinbeard, Don & Debra
 Coleman, Ted & Karyn
 Crebbin, Duncan & Michelle
 Dougy Center
 Draneas, John & Carlyn
 Ellis, Bob & Kathleen
 Falleur, Bob & Susan
 German Metal Works
 Greenwood, Chris
 Gretz, Jeff & Jeannie + Daughter & Son-In-Law
 Guy's Interior Restoration
 Hodge, Greg & Susan
 Jacobsen, Mike & Terri McNabb
 Jewett, Tom & Linda
 Johansen, John
 Knepper, Steve
 Koblegarde, Rupert & Bobby Jo
 Koffel, Betty Lou
 Linsky, Peter
 Locanthi, Bart
 Lowe, Warner & Nadine
 Lukow, Duane & Aaron Hues
 Magnum Opus
 Marque Motors, Leipzig, Kurt & Jackie
 Monarch Hotel
 Nies, Alan
 Neidhart, Jim
 O'Conner, Mike & Mary Chase
 Olson Memorial Pediatric Clinic
 Portland Brewing Company
 Pro Drive
 Ringside Restaurant
 Sironen, Rick & Debbie
 Stoneguard
 Temp Control Mechanical Corp.
 Tigard Optometric Clinic, Drs. Hohner & Freedle
 Tweeks
 West, Chuck
 Widmer Brothers Brewing Company
 Williams, David & Nan

Above and Beyond

Bader, Dick
 Beutz, Tom
 Clinkinbeard, Debbie
 Crebbin, Duncan
 Hodge, Greg & Sue
 Linsky, Peter

Pascoe, Sharon & Russ

End-of-Year Awards

John Mazmanian
 Ken & Sue Blanchard
 Sharon Pasco
 Steve Tarket
 Duncan Crebbin
 Peter Linsky

Chief Track Coordinator, Safety Chairman, Rainbonnet
 Zupan, Rainbonnet, Club Race, Burrito Run, AMLS
 Track, Goodie Store, 1/2 Millie, Zupan, Club Race
 Zupan, AMLS, Goodie Store, Progressive Dinner, Rainbonnet, Club Race
 Editor, Kahneeta, 1/2 Mille, Anzeiger Contributor, Photographer
 Anzeiger Contributor, Insurance Manager, Track, Club Race,
 Rainbonnet, Braille Rallye
 Membership, Braillye Rallye, Nomination Comm.

Enthusiast of the Year
 Family of the Year
 Gear of the Year
 Mark Donohue Award
 President's Award
 President's Award

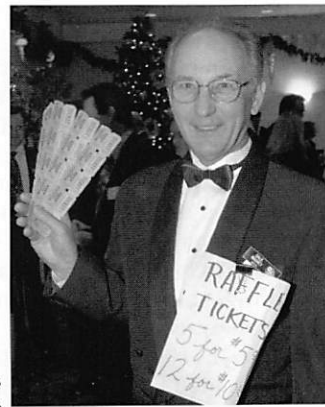

Dale Rhoney is the TicketMaster.

Rainbonnet 2001

by Peter Linsky • Photos by Chris Greenwood

Under the able management of event chairman Duncan Crebbin, Oregon Region's 19th annual presentation of Rainbonnet weekend November 2-3-4 at the Monarch Hotel, proved another success, overcoming the shock of September 11th (Please don't call it "9-11") and a recessionary economy that prompted some regulars to stay home. Duncan and his team assembled a quality program featuring the always-popular indoor concours, a full slate of technical presentations, an endless pile of great door prizes, a menu of top-notch speakers, and the traditional Sunday track session at PIR. Rather than the usual goodie bag, Motorsports International stepped up for good-looking, embroidered golf shirts.

While concours entrants pushed their cars into place in Monarch Hall and began the tedious work of cleaning and polishing their little jewels, the rest of us early arrivals piled into a tasty Tex-Mex buffet hosted by Stuttgart Autotech. Concours chairman Don Clinkinbeard directed cars to their appointed places and began to recruit a panel of judges. After supper, Aloha's Cindy Lux, winner of the 2000 Panoz Global Challenge Championship for the world's top female drivers, shared her experiences in that series and more recent professional seat time in a Porsche GT3R, encouraging the women in attendance to pursue their own racing goals.

Saturday morning found a steady line at the registration table, where Rick and Debby Sironen had all the paperwork under control. After coffee, juice, fruit, and pastries, we headed over to the main ballroom for a day of informative technical seminars. PCA tech guru Bruce Anderson (soon to be elevated to National Tech Guru Emeritus) kicked things off and was well into his slide program when the projector decided to take early retirement,



Above: Putting the wipe on the mirror-like finish of this silver bullet.



Left: Cindi Lux flashes the trademark winning smile.

Right: Judges break out the fine-toothed combs for this pair of concours entries.

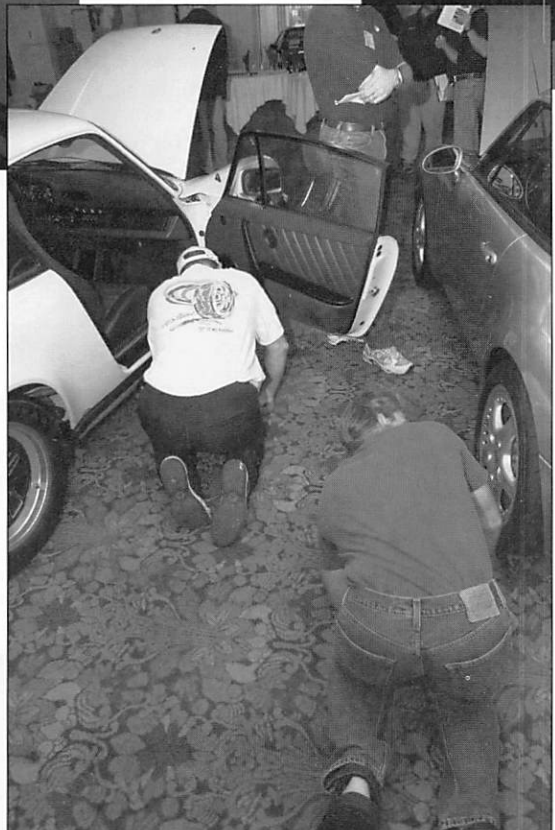

forcing Bruce to ad-lib his way ("Hmmm...let's see...click-click-click...Oh, yes!"). Great job winging it, Bruce! 914 expert Jon Lowe flew in from Alabama to share his thoughts on how to avoid costly mistakes when shopping for a mittel-motor Porsche. Kim Crumb, PCA's Midwest 928 maestro, also knows how to teach driving, and provided some compelling comment on the right way to approach time behind the wheel.

After a break for some great build-your-own deli sandwiches and salads provided by Greenwood Marketing, it

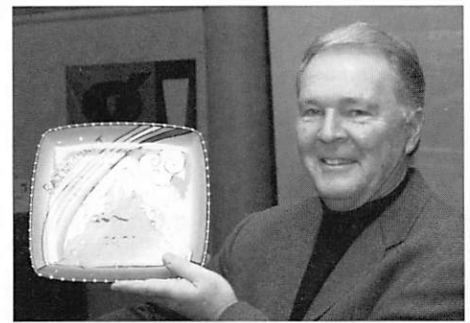

Peter Brock gave a very interesting talk about a few chapters in automotive history, which he helped write.

was back to class, where Bill Burris had run up from LA to expose the electrical secrets of 944 sunroof operation. All the way from New Hampshire, Bruce Whittier and assistant Chris Miller arrived to present a detailed discussion of the newest VarioCam Plus valve timing system used in the

new 996 Turbo. Having learned about Isky camshafts back when "bumps is bumps", your reporter is still trying to absorb this new technology! Bruce represents Robert Bentley Publishing, and brought along a range of technical guides plus some interesting new auto-



motive titles, one of which followed me home. The concluding presenter was Christian Garibaldi, offering a refreshingly different slide show on how to tweak a 930 Turbo for the street. Christian's shop in New Jersey is directly across the street from John Paterek's Porsche restoration business. Chris' personal car is a flat-black (!) beastie that runs on the street without benefit of mufflers, much to the dismay of his neighbors and the local federales. A night-time color slide of his car spitting three-foot bursts of flame from its twin

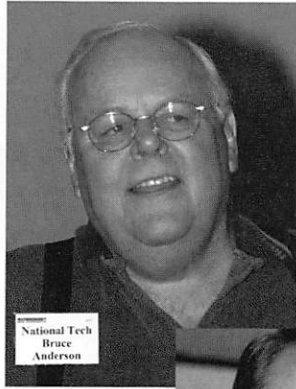

the evening, a rare appearance by Peter Brock.

To begin with, Brock likes Porsches, but he can't be labeled a "Porscheperson"...he's a "car person" in the broadest sense. An insightful automotive writer and a fine photographer, Brock is perhaps best known as the designer of Carroll Shelby's famed Cobra Daytona coupes, winner of the FIA Grand Touring title in 1965. There is, however, much more to the man, and he shared much of his fascinating story with us. Imagine being 22 years old, fresh out of The Art Center School of Design, and going straight to work at General Motors Design under Bill Mitchell! Mitchell got the credit for

the Corvette Stingray, but many of the ideas came from Peter's fertile mind, nourished by the German, Italian, and French styling books and magazines that lay gathering dust in G.M.'s vast research library. From Peter's telling, nobody at G.M. ever bothered to look at them. Top executives were married at the time to conservative, boxy, chrome-laden bodies and outdated chassis design, but Brock was drawn to the push-the-envelope thinking of pre-war German aerodynamics and Italy's swoopy carroseries. He couldn't translate the text, but he understood the graphs concerning coefficient of drag, and mentally filed away the pictures and data that were so far ahead of conventional thought in the '20s and '30s. G.M. didn't want to

pay any attention to him, so Brock headed west, eventually hooking up with Carroll Shelby, who was just starting his own

manufacturing career after a premature retirement from racing.

Peter shared the highs and lows of his years with Shelby, including the development of the Daytona coupe (in a mere 90 days), along with many other inside secrets of that program. Many of the wind-cheating features so common today could be found on Peter's drafting board 35 years ago. We were indeed fortunate to have Peter and his wife Gayle as our guests. Gayle later told me that we were the first audience to see some of Peter's slides. Some, in fact, she had never viewed before.

The evening concluded with Concours Chairman Don Clinkinbeard presenting awards to the class winners. Congratulations to Syd Baker, first in Traditional Full Concours with his sparkling red Speedster, which also claimed People's Choice. Steve Spahr's black Super 90 Roadster captured first place in Traditional Top-only; Scott Bradley's 911 RS clone was the Special Interest class winner; Debbie Clinkinbeard's 993 glass-top Targa won the Pleasure Driving class, and Tom Moore's lovely black 928 was the Daily Driver winner.

Our technical quiz, created by the fiendish Tom Beutz, was conquered by PCA techmeister Jon Lowe, who obviously has a lot of trivia tucked away in his head.

Sunday brought a fleet of cars to PIR for the driver education portion of Rainbonnet. Despite the threat of rain, the skies held off and the track remained

dry until late afternoon. Everyone got in lots of laps.

Altogether, another enjoyable, hands-on Porsche experience. ORPCA sends its thanks to all participants and presenters, and especially our sponsors and many door prize donors. Our gratitude to Sunset Imports, Motorsports International, Stuttgart Autotech, Marque Motors, Guy's Interior Restorations, Duck Delivery, Greenwood Marketing, Temp Control Mechanical, and Roth and Miller Auto Body.

We hope to see all of you back next year!

more photos on page 14



Above: Bob and Kathleen Ellis receive a concours trophy for their beige 911.

Top: Bruce Anderson and Jon Lowe impart substantial expertise for the benefit of Rainbonnet attendees.

exhausts on over-run was worth the price of admission all by itself.

After a couple of hours to unwind, change clothes, and soak up some adult beverages, it was time for the Concours Awards Dinner, hosted by Rob Roseta and our friends at Sunset Imports. Salesman Joel Morgenstern showed us an architect's rendering of Sunset's new Porsche store, soon to begin construction. Another excellent buffet with wine and ale (Thanks again, Portland Brewing), brought us to the real dessert of



One rear-engined fun kar follows another.

Rainbonnet

continued from page 13



Above: Kim Crumb, 928 aficionado by day and by night, takes time to pilot a few vehicles and instruct some "students" during the Rainbonnet track day portion.

Top right: Past President John Draneas likes Rainbonnet if only to "frustrate" agile, near-500-bhp cars with his 110 bhp Spec Racer Ford.

Right: Mike Bartos (at right), one of the many highly prized driving instructors who make our track days and Rainbonnet event possible, consults with a student about the upkeep of his car before heading out onto the track.



Holiday Party

continued from page 11

with the ORPCA logo, sure to be a welcome addition to their touring wardrobes.

Carol received an appreciation gift from our new President, Don Clinkinbeard, and the new members of the Board of Directors were introduced:

Don Clinkinbeard, President
 Ken Blanchard, Vice President
 Pat Jolly, Secretary
 Jeff Gretz, Treasurer
 Board members at Large: Rick Sironen and Don Stroum, Sr.

It was a very enjoyable evening for all who attended. When you bring out your new calendars, mark December 7, 2002, as the date for the ORPCA Holiday party ... you won't want to miss it!!

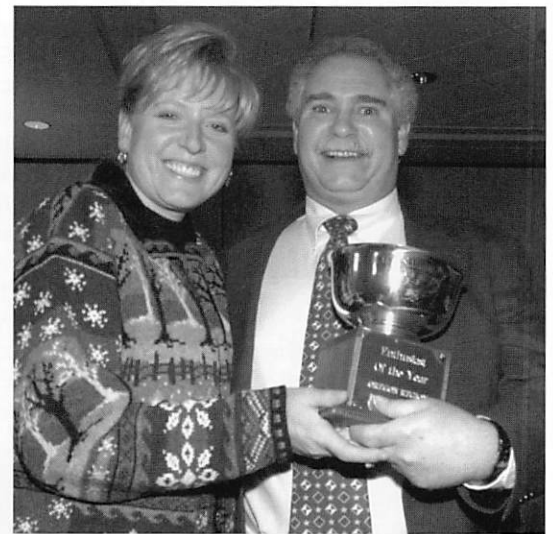

Top Left: Steve Tarket receives the Mark Donohue Award from Michelle Crebbin.

Above: Erica Nance presents John Mazmanian with the Enthusiast of the Year cup.

Left: Ted Coleman announces the silent auction's winning bidders.



GMW Just the Facts:

German Metal Works focuses on custom conversions, specials and outlaws. Besides mechanical and interior, everything is done in house, nothing is contracted out. Jim Nichols has his hands on your project at all times.

All aspects of your project are documented throughout the process with a digital camera. And recorded onto a CD-Rom for your personal records and to enhance the value of your car.

Taught by the best people in the business of collision repair and custom applications, Jim can now teach them a thing or two because of his 21 years of hands-on experience and the opportunities he has had to work on Porsche cars.

You see, there's a lot one can do with a Porsche, from structural repair and chassis-stiffening kits to full roll cages and accessories. Many people can do sheet metal and paint, but Jim pays respect to Porsche's original vision while creating the masterpiece that is your car.

German Metal Works is here for you.
What do you want?

German Metal Works

Your Imagination is our Creation - No Limitations

Specializing in all Porsche models from early 356 to late 911

Sheetmetal Fabrication • Leadwork • Paint



1964 356 prepared for street and vintage racing



Jim installing a factory Speedster nose clip



1973 911 Carrera RS Lightweight restoration (Jim's favorite)

503.753.6699

germanmetalworks.gmw@verizon.net

germanmetalworks.com (coming soon)

Rear View Mirror Quiz

continued from page 8

Answers:

1. c) Porsche's new Quaker State-sponsored Indy car made its track debut at PIR October 7, 1987, with Al Unser, Sr. at the wheel. Factory competition director Norbert Singer and Porsche's North American Racing Director Al Holbert supervised testing ahead of the car's first race at Laguna Seca.

2. d) Erich Strenger was the accomplished artist and early Porsche enthusiast who was recruited to put pen and ink to work celebrating the factory's early triumphs. The other three are authors of books on Porsche.

3. c) Harry Blanchard was the only US driver to finish the 1959 USGP at Sebring, driving that Porsche F2 with the center-seat sportscar body (now restored and appearing regularly in vintage races) to seventh place. Bob Said (father of Boris) drove an old D-type Connaught, Roger Ward

drove the USAC Leader Card Kurtis Offy midget that he shocked everyone with by winning the Formula Libre race at Lime Rock a few months before. Phil Hill drove a Ferrari Dino, and George Constantine had a Cooper T45.

4. d) Al Holbert's father, Bob, was the E Sports racing champ in 1961 and 1962, driving a pair of RS-61's. He crashed the first one at Mosport, and ordered a new car from the factory. The newer chassis had a four-inch longer wheelbase than his old car because it was built to accommodate a 2-liter 8-cylinder engine similar to the F-1 powerplant. The longer wheelbase gave Bob a much better-handling car, and he cruised to the title.

5. b) The correct answer is Jimmy Cagney, playing a New York City hustler in the 1959 movie "Never Steal Anything Small", which appears occasionally on cable's Turner Classics.

Go-Kart Endurance Racing

THE ULTIMATE GIFT OF SPEED

Gift certificates available
\$249.00
Per Driver

- 3 Hour program, 2 Hour Endurance Race with Practice & Qualifying sessions!
- Race will include re-fueling & driver changes.
- Team who completes the most laps wins.
- 4 drivers per kart, all safety gear supplied.

For information call 503-274-1050

 campbell productions
autosports
Explore New Levels of Entertainment Behind the Wheel

ORPCA FUND RAISING PARTNER SERVICE SHOP



DIGITAL FOUR-WHEEL ALIGNMENT NOW AVAILABLE

PORSCHE

AUDI

BMW

SPECIALISTS

17263 S.W. PILKINGTON RD.
LAKE OSWEGO, OR 97035

635-3098

Michael Jordan
Dave Fast
George Forkner
Tony McCabe

Oregon Yacht Sales

New & Brokerage
15' - 150'



JACK GALLUS

865 N.E. Tomahawk Isle Dr.
Suite 103
Portland, OR 97217

Off. (503) 285-5586
Fax (503) 285-2320
Pager (503) 795-5147
Res./Fax (503) 690-0824
Cellular (503) 799-5028

Bill Shores PORSCHE SPECIALIST

Since 1971

Other vehicles and exotics available
shown by appointment only

Distributor for Stongard Transparent Bra
(503) 644-4640 www.billshores.com

PORSCHE 911s WANTED

TOP PRICES PAID FOR
NICE CLEAN CARS

Monte Shelton
MOTOR COMPANY



SAAB

Quality classic and
collectable automobiles

1638 West Burnside • P.O. Box 5545 • Portland, OR 97228
503/224-3232 • FAX 503/224-4310



Chris' Foreign Auto Repair

Chris Baxley



Specialize in Porsche, Audi, Mercedes, BMW, VW,
Honda & Toyota. Other Makes Also Serviced.

4747 West 11th Avenue #C
Eugene, OR 97402
Phone (541) 338-0707



Northwest

Campbell Galt & Newlands

*Partnering to deliver FULLY INTEGRATED
insurance and financial services*

700 NE Multnomah Street, Suite 1300
Portland, OR 97232
Main (503) 224-8390
Fax (503) 224-8319
www.usinw.com

John H. "Skip" Yocom

Vice President

Direct (503) 727-6181

skip_yocom@usi-insurance.com

When Service Counts...

Motor Sports International

- ENGINE
- TRANSMISSION
- SUSPENSION
- TUNE-UP
- OIL CHANGE
- MAINTENANCE

ESTIMATES GLADLY!

Factory-Trained Technicians
Specializing in Porsche, Audi,
BMW and Mercedes-Benz
Since 1974



**Bosch
Authorized
Service**

As your Bosch Authorized Service Specialist we are equipped with the latest test equipment. Our trained technicians are specialists in testing, diagnosing and servicing **ALL EUROPEAN CARS.**

SPECIALISTS IN SERVICING THESE BOSCH SYSTEMS:

- GASOLINE FUEL INJECTION
- DIESEL FUEL INJECTION
- ELECTRONIC SYSTEMS
- ANTI-LOCK BRAKE SYSTEMS
- HYBRID IGNITION
- ACCESSORIES

643-2656

Wayne Ditsworth, Owner/Operator

**12930 NW CORNELL RD
PORTLAND, OR 97229**

(Old Cedar Mills Fire Station)

From the President

continued from page 5

into an event. Please give me a call if you are interested, or I might just step up to you one day soon, tap you on the shoulder, and ask you to help.

The new BOD has had a couple of meetings and ironed out our operating procedures and general responsibilities for the year. In contrast to past years your directors will assume responsibility for functional areas of the club as follows: Competition Events (Pat Jolly); Tours and Rallies (Don Stroum); Social Events and Goodie Store (Don Clinkinbeard); Drivers Ed (Rick Sironen); Financial Management (Jeff Gretz); Communications and Publications (Ken Blanchard); and Special Projects (Carol Beutz). Each of these individuals have been tasked to work with their event chairs to create a vision of where they want to go with each of the programs over the next couple of years and start to develop the people and events needed to get there. If you have any input in any of these areas or new ones not covered, please contact the director listed to give them your input.

We have a preliminary calendar for this year in this issue (and on the web) and it offers something for everyone. If you've been hesitant to come out to play with us, just pick an event and try it - you'll find you will like it. And if you don't, please let us know so we can fix whatever is wrong. This is your club and we need input from you to help meet your expectations.

Well, that's a column full for this month. Look for communications from the other directors in the coming issues of Anzeiger giving you an overview of each of the functional areas and plans for them.

All for now,
-drc-
drcbike@aol.com

Tech Stop

By John Mungst, Metro New York Region

Now and then I get calls from members who are working on their cars, sometimes for the first time. Then they get to a point where they cannot remember how to put things back together. One of the most asked questions is the procedure in doing an oil change on earlier 911s is to not only drain the oil but to remove the plate and screen assembly to clean out as well. Herein lies the problem. The sump plate has an offset drain bolt that will be partially blocked. Looking from the rear of the car the bolt is on the left side pointing directly towards the left tire. This is a simple process but often overlooked during reassembly. Now, for my foolproof solution.

I have mentioned this to members many a time. The best thing you can do before you take it apart, is to take a picture of the assembly with a digital camera if you have the means. I often do this when working on my car. How many of you have disassembled drum brakes on a car only later to guess where the springs should go. Ah ha! Just what I thought! A picture gives you the chance to see what it looked like before you took it apart. Oh, and about those extra parts that you were left with when you put it back together - well, you get the picture. (No pun here.) I have a pail full of these that I have accumulated over the years. They seem to come from nowhere. If you do not have access to a camera or a repair manual, make a simple diagram of the part locations. This will certainly help you in the end.

Porsche Parts
 * Large Used Inventory
 * Rebuilt & Reconditioned Parts
 * New OEM & Aftermarket

Porsche Restoration
 * Body Conversions * Award Winning Paint
 * Collision & Rust Repair * Complete Refinishing

Alpine Imports



PORSCHE
Our Specialty

11 N. Weidler
 Intersection of Weidler and Vancouver
 (At the Rose Quarter)

Call: 503 - 265 - 2261
 WANTED: ANY PORSCHE
 (in any condition)

I'll understand if you look at the garage first!



RE/MAX

EQUITY GROUP, INC.
 Independently Owned and Operated



Gabby Tyer, CRS, GRI

Associate Broker

8555 SW Apple Way, Suite 330 • Portland

Office: 503.297.6202, x121

Mobile/pager: 503.702.0393

FAX: 503.297.7812

E-mail: GabbyTyer@aol.com



AMSOIL Lubrication Without Equal

Greenwood Marketing is pleased to announce the Fund Raising Partnership Program with ORPCA.

Purchasing AMSOIL products from one of the participating service shops or directly from Greenwood Marketing will generate a direct rebate to your Porsche Club.

For more information, call the service shops that display the "ORPCA Fund Raising Partner Service Shop" designation in their advertisements, or call Greenwood Marketing.

Call for a complete catalog of AMSOIL products.

GREENWOOD MARKETING

ORPCA FUND RAISING PARTNER

1-800-722-1092

Gary Emory
 ~ celebrates ~
40 years in the Porsche Parts Business

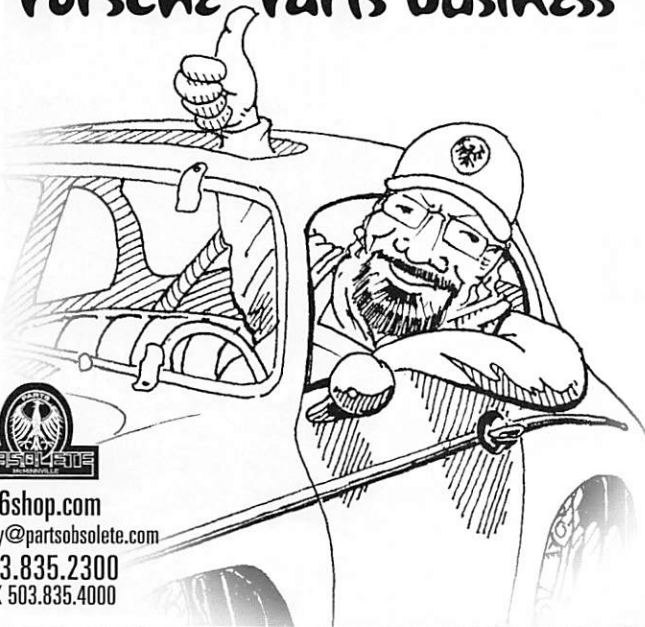

356shop.com
 gary@partsofobolete.com
 503.835.2300
 FAX 503.835.4000

13851 SE Eola Village Rd., McMinnville, OR 97128

Porsche Repair and Restoration



- Full Mechanical Service Department
- Full Body, Refinish and Restoration Department
- Master-Certified Technicians
- 18-month/18,000-mile guarantee
- Financing, O.A.C.
- Ask about our shuttle service

503.771.6701

Click through our web site:
 stevesimports.com



Steve's Personalized Imports
 ~ and ~
Steve's Collision and Restorations

7273 SE 92nd Ave • Portland, OR 97266
 14 blocks south of Foster on SE 92nd

Marketplace

CARS FOR SALE

912/911/930

1998 911 Carrera 2S Coupe

#WPOAA2996WS321083. Black on black, 4,318 mi., widebody, motor sound, ss sills & tips, sunroof, full leather, pwr & htd seats w/ crests, alum dials, carbon fiber e-brake & door latches, titanium shifter, 17" CUP Rims with P-Zeros, lowered, red brake calipers, garaged, non-smoker, last of the best, forever air, \$71,000. **Andy**, 11925 N.E. Lauren Lane, Newberg, OR 97132, (503) 537-1115. 01.02

1996 911 Carrera Coupe, original owner, low mileage, award winning. Black on Black. Digital Sound. Leather and wood steering wheel, Handbrake, Gear shift. Porsche performance mufflers and air box. Loaded with factory extras! Extended warranty remaining. Absolutely beautiful!! Asking \$64,295. **John Lewis**, (503)363-7889 or (541) 928-6234. 01.02

1980 Porsche 911 SC Weissach Edition, platinum colored, sunroof coupe with factory spoilers, AC., PW, leather interior, cd player, new paint and professionally polished, new tires, runs smooth. \$21,000 OBO. **Gordon** (503) 684-3904. 12.01

1976 911S Targa, Yellow/Tan interior. S/N=9116211706, 192k Miles. Very good condition. Local car, owned since 94, always garaged. Reasonable offers considered. **Chuck** 360-833-8709 or vanwa@pacifier.com. 12.01

1988 911SC Carrera Targa, 3.2 liter engine, 5-speed, black-on-black, 16" detailed Fuchs, CC, PW, PL, P-seats, A/C, Leather, Rear Wiper, Alarm, New Tires, New Kenwood security rotating-face-plate AM/FM CD Stereo & 4-channel Amp, 90k miles, \$22,900, (503) 293-1799. 12.01

993

1995 993 with 5k original miles. Guards red/black, sunroof, 6 speed, ABD, 17" wheels with color crests, AM/FM Cass with CD Changer, hi-fi sound. Always garaged, no winters. Showroom condition. \$55,000. (503) 723-6146 01.02

928

1979 928 One owner, 93K original easy TLC miles. black/black(schwarzx2) Runs like a dream. All service records (Motor Sports International). \$15 K-best offer. **G.R.Schwarz**, M.D. (503) 292-9616. 01.02

PARTS FOR SALE

Set of Four 18" OZ RACING Wheels with Goodrich G-Force tires (tires have a couple of track days left - wheels are like new) f: 18 x 8 r: 18 x 9.5 Set was purchased last year from TireRack for \$2,000. SALE !!! Only \$1000. Contact **Steve Shinsel**: shinsel@easystreet.com or (503) 690-1705. More info/Pictures at <http://www.shinsel.com/wheels> 01.02

Set of 16 inch Porsche Boxster with Bridgestone Blizzard snow tires for sale. Save money. Set of 4: \$650 **Robert** (503) 669-0520 or sordello@earthlink.net 01.02

2 Koni front shock inserts (a few dents, and surface paint blemishes, but work fine) — for Carrera type struts; 2 KYB rear shocks (from a 1973 911); Left & Right adjustable rear spring plates (Weltmeister type); Left & Right banana arms (rear trailing arms - steel, from a 1973 911) (541) 689-1460, or xrw@att.net 01.02

Wheels, wheels, wheels! (2) 6x16, (2) 7x16 Fuch 911 23.3 polished lip, spokes, cap and blk.centers. (Art stearus - skip) \$950; (4) 7Jx15 ATS ET 23.3 951.362.104.00 phone dials. Polished lip, ovals, crest, met. Blk centers w/ ok tires. \$650; (4) 7x16 928.361.016.00 need refinishing, track day? \$475; (1) 8Jx16 23.3 Fuch 944, dinged, \$125; (1) ET 53 6Jx16 AS 10.62 flat disk 924 turbo? Dinged, \$75. **Mike Baker** (360) 574-9420, (541) 593-2980. 01.02

911 Odds and ends: One pair of used SC Turbo valve covers, perfect, \$50.00 OBO; used five-blade cooling fan from a 1977 2.7 911S, 240MM, good condition, \$15.00; V-belts for 2.7 911S: New OEM, (2) 9.5 x 7.25 999 192 0977 050, (1) 9.5 x 9.50 900 192 021 50, \$10.00 for all three. **Peter Linsky**, (503) 644-2709 evenings. 12.01.

Set of 993 BBS 3-piece cup race wheels, Porsche Cup P Zero Slicks. Used once on track day. 245\645-18 fronts and 285\645-18 rears. \$3,500. **Steve Thayer** (360) 694-8290, (360) 607-2658 or fax: (360) 694-7921. 12.01

Please send all classified ads to:

Classified Editor
Kirsten Fasching & Craig Oty
232.4892
anzeigerclassified@earthlink.net

Classified ads are free to PCA/OR members. Limit 50 words per ad. Ads may also be edited and abbreviated according to available space.

PLEASE NOTE: Ad will run for two issues. Renewal of ad may be made by calling the Classified Editor.

Non-members may place one non-commercial classified ad, 50 words or less, for \$12.50 each issue. Include a check made payable to Oregon Region PCA with the ad text. Placement of non-member classified ads depend on the availability of space after all member ads have been included. All ads must be submitted to the assistant editor by the 15th of any given month.

Factory 7/8x15 Fuchs alloys, black centers, no caps, typical scratches and chips, great for track, auto-x or non-concours street applications, \$700. Used 5pt TRW harnesses, red, no mounting hardware, \$35. Split shipping on above. Contact **Doug** at skinnerd@lsil.com or (503) 246-7067. 12.01

A set of five spoke 17 inch Brushed Aluminum Mag Cup Wheels with Porsche crest wheel caps, and a set of Sumitomo HTR 402 Tires [on my 1988 911 Carrera] Size of wheels are: Front 7 1/2- J 17 and Rear 9J-17 Sumitomo Tire size 205/50ZR17 front , and 255/40ZR17. Only \$900 for a full set of wheels and tires. Contact **David** (503) 653-6052 or seigneur2@home.com. 12.01

WANTED

Enamel 3 1/2" diameter ORPCA grille badge and mounting bracket in good to excellent condition. **Peter Linsky**, (503) 644.2709 evenings. 12.01

503.236.2106

A-n-T

TIRE AND WHEEL

Shop the "tire discounters," then call us!

~ Serving the Porsche Club for 25 years ~
Specializing in high-performance street and track applications.

Additional Services: Alignment • Brakes • Shocks • Lube • Oil • Filters

437 SE MLK Jr Blvd • Portland, Oregon • 97214

Wings and flares. Nuts and bolts.

- New, used & rebuilt Porsche parts
- All years. all models: 356, 911, 912, 914, 924, 944, 968, 928, 930
- All used parts from rust-free CA cars
- Friendly, knowledgeable staff
- We ship UPS daily
- Mon-Fri: 8-5, Sat: 9-3 Pacific Time

800.767.7250

Tel 510.782.0354 Fax 510.782.0358
www.partsheaven.com

PARTSHEAVEN

COMPLEMENT YOUR DRIVING SKILLS



TAKE A SPIN
IN THE SKIDCAR™



503.285.4449
www.prodrive.net

GUY'S

INTERIOR RESTORATIONS

FULL-SERVICE AUTO UPHOLSTERY
ORIGINAL & CUSTOM INTERIORS

Sports, Luxury, Exotic and Classics
Foreign and Domestic

CONVERTIBLE TOPS - A SPECIALTY

LEATHER RESTORATION
DYEING AND COLOR MATCHING

The Finest
Upholstery
for Your Car

Guy Recordon

Jim Enger

503/224-8657

431 NW 9th Avenue
Portland, Oregon

97209



Over
250 years
combined
experience.

Factory-
trained
mechanics.

Air-cooled
specialists.

2327 SE Powell Blvd
Portland, OR

503.233.4809

Board of Directors ORPCA

President

Don Clinkinbeard
8659 SW Muledeer Dr
Beaverton, OR 97007
Hm. 503.356.1764
drbike@aol.com

Vice President

Ken Blanchard
4679 NW Huserik Dr
Portland, OR 97229
503.849.8297
AESLLC@aol.com

Secretary

Pat Jolly
18785 SW Alderwood
Beaverton, OR 97006
503.649.9127
jollypa@uswest.net

Treasurer

Jeff Gretz
16799 SW McFee Pl
Hillsboro, OR 97123
503.628.6253
gretz@omtool.com

Goodie Store

Michelle Crebbin
dmcac85@home.com

Past President

Carol Beutz
12170 SW 124th Av
Tigard, OR 97223
Hm. 503.521.9413
Wk. 503.431.4990 (Sept - June)
cbeutz@msn.com

Board Members at Large

Rick Sironen
3103 NE Rocky Butte Rd.
Portland, OR 97220
Hm. 503.257.9912
Rsironen@uswest.net

Don Stroum

4040 Imperial Dr
West Linn, OR 97068
503.722.1350
dstroum@attbi.com

PCA Zone 6 Rep

Dick Grant
253.813.1930
woosh@aol.com

Webmaster

Rick Thacker
rick_nw@msn.com

Advertising Manager

Chris Greenwood

Circulation/Membership

Russ & Sharon Pascoe
503.362.1145
russpascoe@hotmail.com

Contributing Editor

Peter Linsky
503.644.2709
Linsky911@aol.com

-Anzeiger-

Editor

Sue Hodge
503.518.9203
sghodge@bctonline.com

Classified Advertising

Kirsten Fasching & Craig Oty
503.232.4892
anzeigerclassified@earthlink.net

Contributing Editor

Chris Greenwood
503.460.9494
chris@chrisgreenwood.com



Board meetings of the ORPCA will be held on the first
Tuesday of the month at 6:30 pm
Consult oregonpca.org for the latest information

OREGON REGION PCA Board Meeting Minutes November 6, 2001

The Board of Directors of Porsche Club of America, Oregon Region, an Oregon non-profit corporation met for its duly called monthly planning meeting on the date indicated above.

1. ATTENDANCE.

1.1. Board members present were: Carol Beutz, President; Don Clinkinbeard, Vice President; Mike Jacobsen, Treasurer; Erica Knutson-Nance, Secretary; John Draneas, Past President; Michelle Crebbin and Rick Sironen, Board members at large.

1.2. Also in attendance was Greg Hodge.

2. LOCATION.

2.3. The meeting was held at The Vista Springs Cafe.

3. MEETING.

3.4. President Carol Beutz, who presented the agenda, called the meeting to order at 6:40 PM. After Mike Jacobsen made motion to approve the October minutes Michelle Crebbin seconded the motion.

3.5. Treasurer's Report.

3.5.1. Mike Jacobsen gave the Treasurer's report. Rick Sironen gave motion to approve as read. The report was approved.

3.6. Membership report.

3.6.2. No membership report.

3.7. Anzeiger.

3.7.3. No Anzeiger report.

3.8. Web site.

3.8.4. No Web site report.

4. OLD BUSINESS.

4.9. Open Action Items

4.9.5. Charities Report - Carol Beutz reported that she has not been able to contact Parker Johnstone. Rick Sironen made a motion that proceeds from the Silent Auction from the Holiday Party go to the Doughy Center and the Raphael House. Erica Knutson-Nance seconded the motion. Motion passed.

4.10. Board Liaison Report

4.10.6. Planning Meeting - The meeting will be held at the Sweetbrier Inn on November 18, 2001. Please RSVP with Nancy Herron

4.10.7. Holiday Party - Carol Beutz reported that the Holiday Party is coming along fine.

4.10.8. Rainbonnet - Rick Sironen reported that there were 130 people at dinner Saturday night and everyone enjoyed the evening. Track Day went well, and there were 24 people who came out that hadn't registered prior to the event. Peter Linsky will write an article about Rainbonnet for the Anzeiger.

4.10.9. Dinner Gathering - The Dinner Gathering will be held at Stuffed Pizza on November 15, 2001.

5. NEW BUSINESS.

5.11. Go Carting on ORPCA Track Days - Ross Dyer contacted Don Clinkinbeard about the possibility of sharing the track to help cut back on track costs. Peter Linsky is checking out the possibility with PCA insurance. The go-carts would not effect the time we use the track to run our sessions. The Board agreed that if we get the OK from PCA that this would be a great addition to our track days.

5.12. Swap Meet - Don Clinkinbeard was contacted by Colby about an idea he has for promoting the ORPCA. On November 17, 2001 from 8:00-6:00 there will be Swap meet at the Expo Center that the ORPCA has been offered a free booth. We will be given 4 passes and room to display 1 car. We will not be selling anything but answering questions about the club. The Board agreed it is a great idea and if we could find a couple of volunteers we should do it.

5.13. Expense Reimbursements - Rick Sironen suggested that it would be appropriate for the Board to formalize our procedures and policies regarding the reimbursement of volunteers for expenses they incur in connection with Club business. 1. Rick moved, and Don Clinkinbeard seconded, that reimbursements for expenses other than mileage be limited to reimbursement of out-of-pocket expenses supported by commercial receipts. The motion passed unanimously. The Board also decided to develop a formalized Travel Log to be used by members to track reimbursable mileage (such as when setting up a route for a driving event, (tour, rallye, etc.) 2. Rick also made a motion that all participants at all events should pay the same per level of service received. The motion was tabled till January's Board meeting.

5.14. New Anzeiger Team - Don Clinkinbeard requested that the club spend \$3,500.00, for new software/computer equipment to be used for publishing the Anzeiger. Michelle Crebbin asked that before we proceed with the purchase, we formalize a new contract with Chris Greenwood about his phase out and training of the new Anzeiger Team for 2002 to be reviewed by the Board. John Draneas will contact Chris to finalize his contact. Don Clinkinbeard will continue to do research on software programs and computers to present for approval.

Meeting adjourned at 9:35 PM.
Respectfully submitted:
Erica B. Knutson-Nance
Secretary
19 November, 01



2002 Board of Directors (L-R)

VP Ken Blanchard
Jeff Gretz Treasurer
Don Stroum Board Member at Large
Pat Jolly Secretary
Rick Sironen Board Member at Large
President Don Clinkinbeard
Past President Carol Beutz (not pictured)

Marque Motors recommends seat belt usage and observance of all traffic laws at all times



We don't have a crystal ball... we have the tools and the talent.

Marque Motors has the tools and the talent to communicate with your car.

We keep up with the times. 356, 911, 928, 944, 930, 968, 996.

At Marque Motors we don't just specialize in Porsches, we live them, we understand them.

Come to Marque Motors for:

Factory scheduled service maintenance

Performance modifications

Pre-purchase inspections

Four-wheel alignment

Corner weighting

Large parts inventory

Over-the-counter sales

Brakes and oil change

Electrical repair

Fuel injection

Porsche, Audi, BMW, & Volkswagen

At Marque Motors the next best thing to working on Porsches is talking about them. Visit our website for tech tips, product updates, information, and more. www.marquemotors.com



Marque Motors

PORSCHE • AUDI SPECIALISTS
MAINTENANCE AND REPAIR

503 293 5386

www.marquemotors.com

7310 S.W. MACADAM AVE. PORTLAND, OREGON 97219

ORPCA Fund Raising Partner Service Shop

Call for an appointment or just drop by.

PORSCHE®

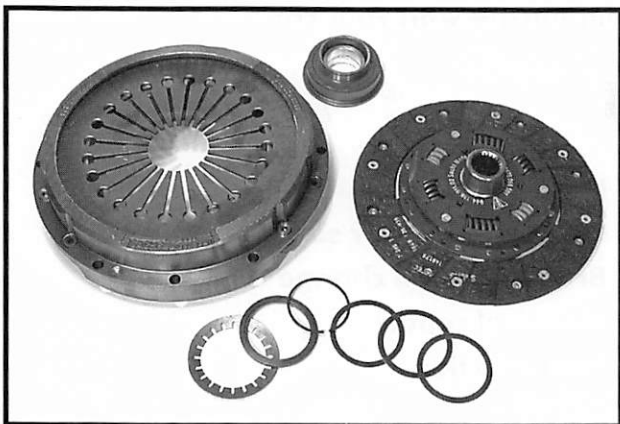
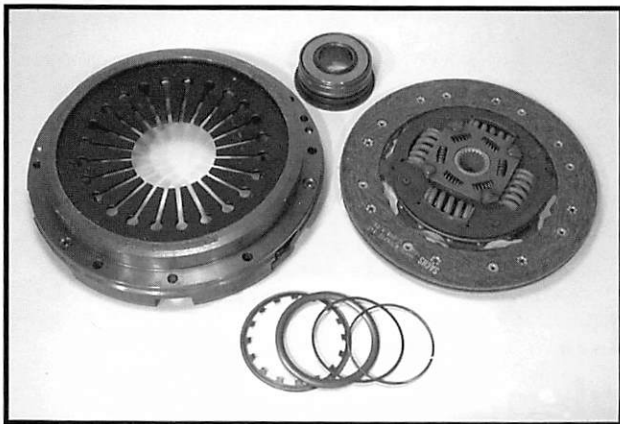
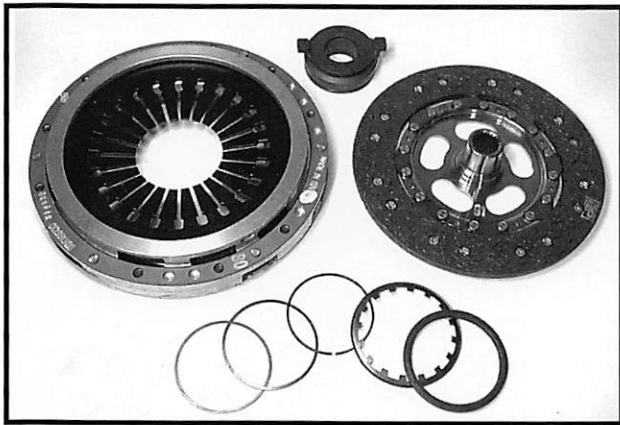

Clutch Kit Specials

We negotiated a special purchase from Porsche that allows us to offer you some of the most popular clutch kits at incredible savings.

Act now, these special prices are limited to stock on hand.

Clutch Kit 944.116.911.00

Retail \$767.05 **Special Price \$299.00**
You Save \$468.05

Clutch Kit 951.116.911.00

Retail \$912.87 **Special Price \$399.00**
You Save \$513.87

Clutch Kit 993.116.911.01

Retail \$750.00 **Special Price \$349.00**
You Save \$401.00

*Unsure which kit fits your car?
Give us a call.*

No other discounts apply. Limited to stock on hand.

Sunset Imports



4050 SW 139th Way

Beaverton, Oregon 97005

503.641.8600 or 800.346.0182

Parts Department Hours: Mon-Fri 8am-6pm • Sat 9am-12noon

www.sunsetimports.com

Anzeiger OREGON REGION PCA
PO Box 5652 - PORTLAND, OR 97228-5652

PRESRTD STD MAIL
U.S. POSTAGE
PAID
PORTLAND, OR
PERMIT No. 1129